



SPHX

PowerTone Explosion Proof Speaker

CPG Signals
 2519 4th Avenue, Moline, Illinois 61265
 P.O. Box 590, Moline, Illinois 61266-0590
 Phone: (800) 577-5758 Local: (309) 762-0731 Fax: (309) 762-8215
 Internet: www.cpgsignals.com



Description

CPG Signals Model SPHX PowerTone® Explosion-proof Speaker is designed for use in hazardous locations. The unit produces a crisp, clear, high decibel tone/voice output. Tones may be generated by the PowerTone Signaling System or any 25 Vrms or 70 Vrms tone/voice audio system.

The speaker cone and projector are of spun aluminum. The speaker driver and circuitry are contained in a explosion-proof housing. The speaker has a supervisory DC coupling capacitor and wattage taps from 0.5 to 15 watts. The speaker is listed for indoor or outdoor use, is NEMA 3 rated, and is finished in red enamel. The PowerTone speaker is designed for connection to system supervised alarm notification circuits.

Weatherproof corrosion-resistant surface mount speaker is required.

Application

The PowerTone speaker is well suited for signaling in hazardous areas with high ambient noise levels where a high efficiency, weatherproof and corrosion-resistant surface mount speaker is required. The speaker is designed for locations where the danger of explosion or fire exists.

The speaker is suitable for use in National Electrical Code (NFPA 70): Class I, Groups B, C, and D, Division 1 hazardous locations. The speaker may be used with any 25 Vrms or 70 Vrms audio system. The speaker can be mounted indoor or outdoor. The SPHX is NEMA 3 rated.



Features

- Operates on 25 Vrms or 70 Vrms signal lines.
- Multiple power taps @ 0.5, 1, 2, 7, and 15 watts.
- High dB output for coverage of large areas.
- UL sound pressure level 99 dB(A) at 10 feet. (see chart)
- Built-In 15 watt high efficiency compression driver.
- Rugged explosion-proof circuitry housing.
- Wide frequency response, 400 4000 Hz.
- Supervisory capacitor.
- NEMA 3 rated enclosure.
- Indoor or outdoor mounting.

Ordering Information

Model Number	Part Number	Description
SPHX-DVSMR	SPHX-DVSMR	Explosion-proof Speaker, Surface Mount, 25 VRMS or 70 VRMS, Red.



SPHX

PowerTone Explosion Proof Speaker

Model SPHX Explosion-proof Speaker Specifications						
Model	Nominal Input Voltage	Frequency Response	UL dB(A) Sound Pressure	dB(A) Sound Power	Dimensions	Shipping Weight (approx.)
SPHX-DVSMR	25 or 70Vrms	400 - 4000Hz	99 ¹	116.8 ¹	14 ¹³ / ₁₆ "H x 8 ³ / ₈ "W x 14 ³ / ₄ "D	15 lbs.

NOTES:

1. Based on wattage tap selected. See dB chart below for specific dB output for each tap setting.

Model SPHX dB Specifications		
Wattage Tap	UL dB(A) Sound Pressure	dB(A) Sound Power
0.5	87	104.2
1	90	106.8
2	93	109.6
7	99	114.2
15	99	116.8

HAZARDOUS LOCATIONS		
Class	Group	Division
I	B, C, D	1

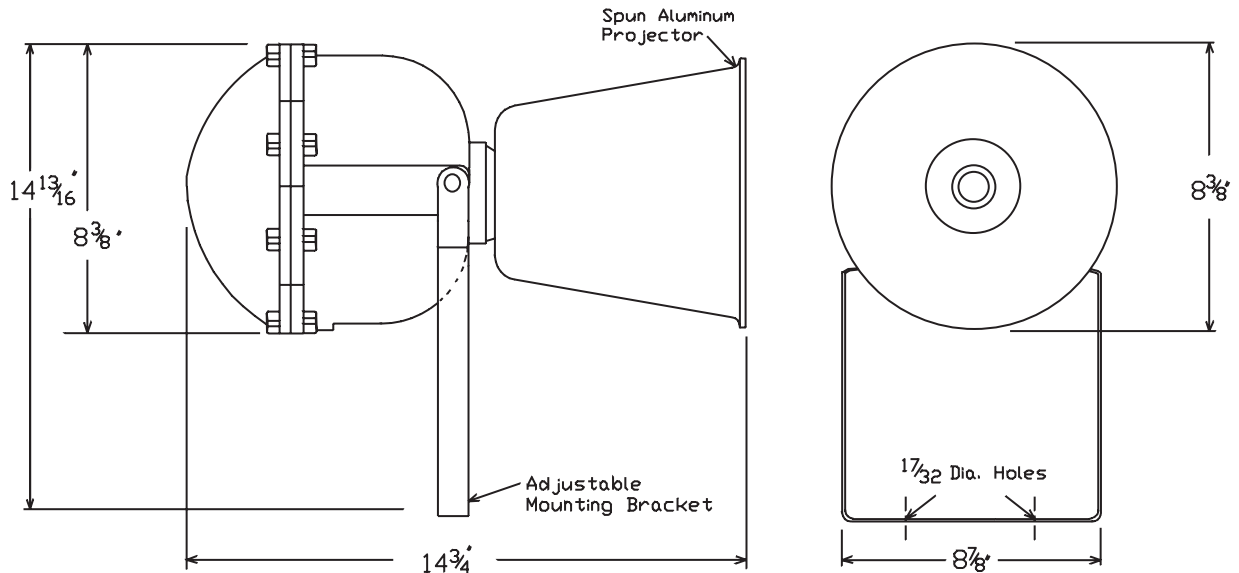

NOTICE: The information contained in this document is intended only as a summary and is subject to change without notice. The devices described in this document have specific instruction sheets which cover various technical, limitation and liability information. Copies of these instruction sheets and the General Product Warning and Limitations Document, which also contains important information are provided with the product and are available from Harrington Signal Inc. Fire Alarm. Information contained in these documents should be consulted before specifying or using the product. For further information or assistance concerning particular problems contact Harrington Signal Inc. Harrington Signal Inc. Fire Alarm reserves the right to change specifications without notice.