

SPHH

POWERTONE® SPEAKERS

SAFETY MESSAGE TO INSTALLERS

People's lives depend on your safe installation of our products. It is important to read, understand and follow all instructions shipped with this product. Listed below are some other important safety instructions and precautions you should follow:

- This unit must be installed by a qualified electrician in accordance with NFPA 72, and National and local Electrical and Fire Codes, under the direction of the authority having jurisdiction.
- Do not connect this unit to system wiring when circuits are energized.
- For optimum sound distribution do not install this device where objects would block any portion of front of speaker.
- All effective warning speakers produce loud sounds which, in certain circumstances, may cause permanent hearing loss. Take appropriate precautions such as wearing hearing protection. Recommendations in OSHA Sound Level Standard (29 CFR 1910) should not be exceeded.
- After installation and completion of initial system test, a program for periodic testing of this device must be established. Refer to NFPA 72, local Fire Codes and the authority having jurisdiction for this information.
- After installation and completion of initial system test provide a copy of this instruction sheet to all personnel responsible for operation, periodic testing and maintenance of this equipment.

Failure to follow all safety precautions and instructions may result in property damage, serious injury, or death to you and others.

I. GENERAL.

The PowerTone Model SPHH is a 25 Vrms and 70 Vrms, indoor/outdoor rated, selectable power output (0.5 to 15 watts) loudspeaker for use with fire alarm signaling systems such as CPG's PowerTone system. It is designed to reproduce electronically generated warning tones, which command rapid recognition, and full range voice communi-

cation. It is suitable for use in areas with high ambient noise levels. This speaker is equipped with a blocking capacitor to allow use in supervised alarm signaling systems. The PowerTone Model SPHH speaker is suitable for use in Class I, Groups A, B, C, & D, Division 2; Class II, Groups F & G, Division 2; and Class III hazardous locations. The speaker projector is adjustable and may be repositioned to obtain desired sound distribution.

II. SPECIFICATIONS.

Operating Voltage	25 Vrms or 70 Vrms
Power Input (selectable)	0.5 W, 1 W, 2 W, 7 W and 15 W
Weight (approx.)	5 lb. (2.25kg)
Size	11-7/8" (302mm) high, 8-1/8" (206mm) wide, 8" (203mm) deep.
Construction	Aluminum enclosure painted with red enamel. Amplifier housing sealed with neoprene rubber gasket. External mounting bracket on Model SPHH.

Listings:

Underwriters Laboratories Inc.
 Model SPHH: File E190743 (Guide UGKZ) Listed as an "AUDIBLE SIGNAL DEVICE FOR USE IN HAZARDOUS LOCATIONS".

Audibility information is shown in table 1.

III. INSTALLATION.

A. Unpacking.

After unpacking the speaker, examine it carefully for possible damage that may have occurred in transit. If equipment has been damaged, immediately file a claim with the carrier stating extent of damage. Carefully check all shipping labels and tags for special instructions before removing or destroying them.

B. Mounting Arrangements (see figure 1).

CAUTION

To maintain the hazardous location rating of the Model SPHH, do not use the 7/8" knockout (concealed conduit mounting).

POWER TAP	UL SOUND LEVEL @ 10' dB(A)
0.5watt	87
1 watt	93
2 watt	96
7 watt	99
15 watt	102

Table 1. Power Tap Setting vs. Sound Output.

The speaker can be mounted on any relatively flat surface. Conduit connection can be made to two 1/2" threaded openings at the bottom of the housing or to 7/8" knockout in rear of housing. A 1/2" conduit plug is supplied for field installation if one of the 1/2" threaded openings is not utilized. After the mounting location and mounting method have been selected, proceed with the applicable instructions below.

WARNING

Property damage, serious injury, or death could occur if an accumulation of water, snow, dust, etc. resides in the speaker projector, severely reducing or preventing operation of this device. Mount the unit so speaker projector is pointed horizontally or slightly downward.

1. Flat Surface Mounting

a. Remove and retain the two screws that secure cover to housing. Remove the cover.

WARNING

Property damage, serious injury, or death could occur if any objects are in front of speaker, severely reducing optimum sound distribution. For maxi-

imum effectiveness, ensure that the front of the speaker is clear of obstructions.

b. Select the mounting location and place rear of housing against mounting surface.

c. Using the mounting holes (four (4) in external mounting bracket) as a template, scribe drill position marks on the mounting surface. See figure 1 for mounting hole locations and dimensions.

CAUTION

Before drilling holes in any surface, ensure that both sides of surface are clear of items that could be damaged.

d. Secure the unit to a wooden mounting surface with #10 x 1" wood screws. If mounting on a metal surface, drill 13/64" diameter holes and secure the unit with #10 screws, lockwashers and nuts.

e. Route power and supervision leads through conduit to the audible signal. Install a 1/2" electrical connector at the bottom of the audible signal. Route wires through conduit and electrical connector into the audible signal housing. Install supplied 1/2" conduit plug if only one 1/2" conduit entrance is used.

WARNING

Property damage, serious injury or death could occur if the projector is mishandled during installation or over time. DO NOT rotate the projector more than 180 degrees or internal speaker wiring may be damaged.

f. Reposition speaker projector if necessary to obtain desired sound coverage. Loosen collar nut (see figure 1) and move projector to desired position.

g. Before reinstalling the housing cover, read paragraph III.C. Electrical Connections below and make the necessary electrical connections.

C. Electrical Connections.

DANGER

To avoid electrical shock, do not connect wires when circuits are energized.

National Electrical Code as well as local codes must be adhered to in installation of these models. All electrical wiring must be routed through approved conduit and fittings.

1. See figures 2 and 3. Connect the audio common (-) leads to the speaker's common terminal and audio positive (+) leads to desired wattage terminal.

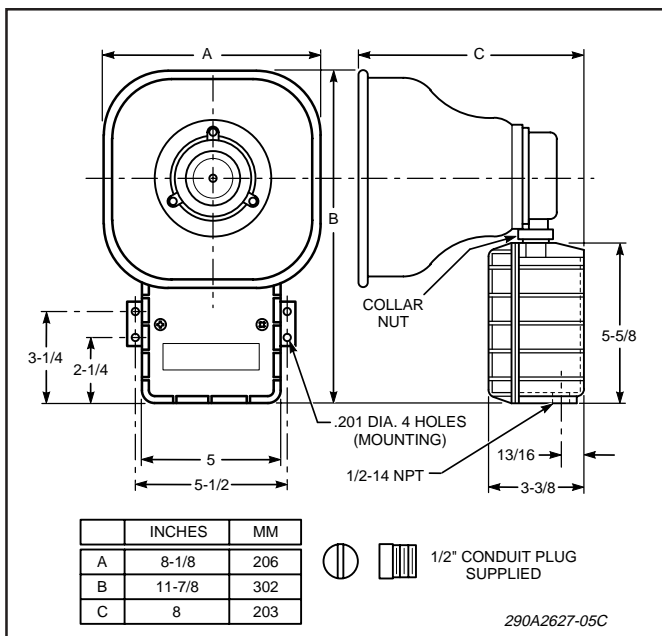

Figure 1. Speaker Dimensions.

WARNING

An uninsulated section of a single conductor must NOT be looped around a terminal and used as two separate connections. NFPA 72 requires that the wire is severed to provide electrical supervision of the connection.

2. See Figure 3. Connect the yellow lead, found in the speaker, to the 25V or 70V terminal as appropriate.

WARNING

Property damage, serious injury, or death could occur if the housing is not closed properly. To reduce possibility of explosion, the Model SPHH's housing cover must be kept tight while circuits are energized.

3. Be sure the neoprene rubber cover gasket is properly seated in the housing groove and reinstall the housing cover.

IV. TESTING/OPERATING.**WARNING**

Under certain conditions these devices are capable of producing sounds loud enough to cause hearing damage. Adequate hearing protection should be worn if standing within close proximity to device while testing. Recommendations in the OSHA Sound Level Standard (29 CFR 1910) should not be exceeded.

A. After installation is complete, be sure to test the system to verify that each speaker operates satisfactorily. If it is found that the unit is too loud for its location, a lower wattage tap may be selected. Carefully remove the housing cover and move the positive (+) lead to a lower wattage tap (see Figure 3). Reinstall the housing cover and retest.

WARNING

Property damage, serious injury, or death could occur if the housing is not closed properly. To reduce possibility of explosion, housing cover must be kept tight while circuits are energized.

B. After completion of initial system test, establish a program for periodic testing of this device. Refer to NFPA 72, local Fire Codes and the authority having jurisdiction for this information.

C. Provide a copy of these instructions for the Safety Engineer, system operator(s) and maintenance personnel.

SAFETY MESSAGE TO OPERATORS

Even if your warning system is operating properly, it may not be completely effective. People may not

hear or heed your warning signal. You must recognize this fact and ensure that your warning signal achieves its intended effect through proper test/training sequences within your specific application(s).

V. MAINTENANCE.**SAFETY MESSAGE
TO
MAINTENANCE PERSONNEL**

Failure to follow all safety precautions and instructions may result in property damage, serious injury, or death to you or others.

- Read and understand all instructions before performing maintenance on this unit.
- To reduce the risk of electrical shock or ignition of hazardous atmospheres, do not perform maintenance or service on this unit when circuits are energized.
- Periodic checks should be made to ensure that effectiveness of this device has not been reduced because speaker has become clogged with a foreign substance or because objects have been placed in front of the speaker.
- Any maintenance to this unit MUST be performed by a trained electrician in accordance with NEC guidelines and local codes.
- Never alter this unit in any manner. Safety in hazardous locations may be jeopardized if additional openings or alterations are made to Model SPHH.
- The nameplates, which contain cautionary or other information of importance to maintenance personnel, should not be obscured if exterior of device is painted.

A. Periodically check this device to verify that there are no foreign substances in, or in front of, the speaker which will reduce its effectiveness.

B. Testing should be periodically performed. Refer to NFPA 72, local Fire Codes and the authority having jurisdiction for information.

C. In the event a volume adjustment or other repair is required, be sure to refer to the Safety Message For Maintenance Personnel before proceeding.

WARNING

Unauthorized repair/servicing of the unit may result in degradation of performance and/or property damage, serious injury, or death to you or others. If a malfunctioning unit is encountered, do not attempt any field repair/retrofit of parts.

VI. SERVICE.

This product is covered by a 5 year limited warranty. See CPG terms and conditions for details.

The factory will service your equipment or provide technical assistance with any problem that cannot be handled locally with satisfaction or promptness.

If any unit is returned to factory for repair, it can be accepted only if we are notified by mail or phone in advance of its arrival. Such notice should clearly indicate service requested and give all pertinent information regarding nature of problem and, if possible, its cause.

Communications and shipments should be addressed to:

Technical Service Department
 Commercial Products Group
 2519 - 4th Avenue
 Moline, IL 61265
 800.521.8219 • FAX 800.225.4109

PowerTone is a registered trademark of Commercial Products Group.

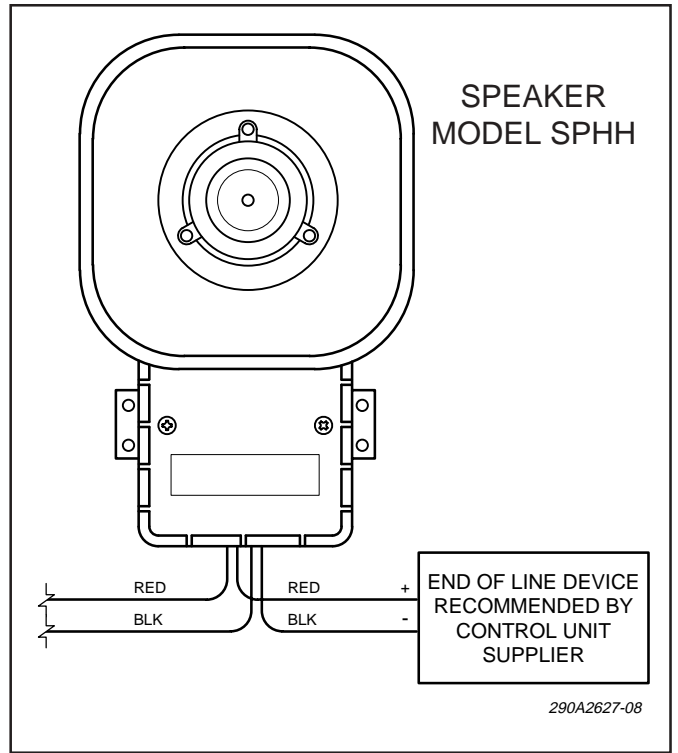

Figure 2. Typical Installation Wiring.

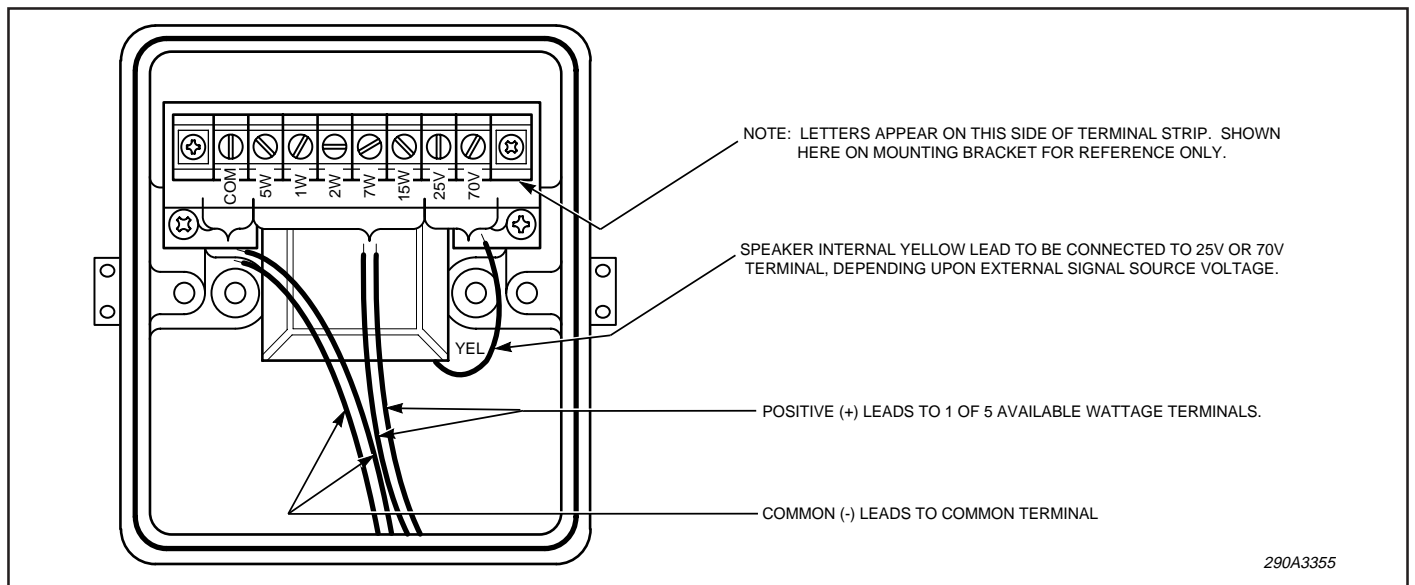

Figure 3. Internal Multi-tap Wiring Set-up.